

E225

Axial Flux BLDC Motor

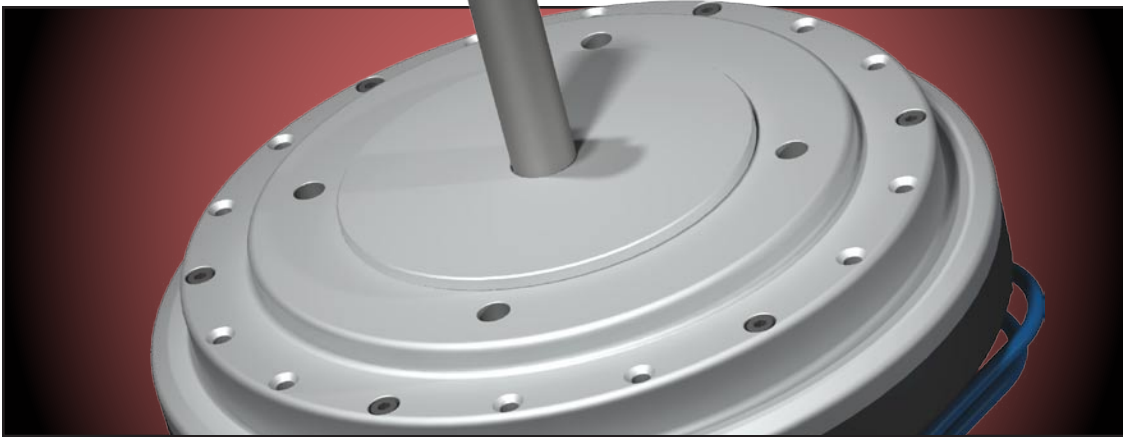

Typical Applications

- Compressors/Blowers
- Servo Applications
- Precision Robotics
- Marine Propulsion
- Generators
- Weapons Turrets

Application Information

- Requires 3-phase H-bridge PWM inverter, available through Lynx
- Performance ratings based on air-cooled 105°C winding, 25°C ambient air
- Developed for use in a high-efficiency air-moving application

Standard Features

- Brushless axial flux design
- Use of patented SEMA coil provides superior power density
- Ironless design eliminates cogging torque
- Extremely linear torque constant independent of speed

The E225 motor was developed to serve as part of a permanent-magnet motor system for air-handling applications, where system efficiency is a high priority. When coupled with its 3-phase H-bridge inverter, this motor offers a highly efficient motor/inverter combination with the high peak torque capability required for the most demanding high-transient applications, including fuel-cell air compressors.

In addition to the E225, a number of other coil configurations for this frame size are under development that exhibit a wide variety of desired motor characteristics. The resulting family of 225 mm motor designs, currently being developed with government and commercial partners, will offer a broad range of possible system configurations for speed and position servo applications requiring both high efficiency and high torque.

The specifications provided here illustrate some of the E225's extraordinary capabilities. For example, the E225 achieves a very high peak-to-continuous torque ratio and high peak efficiency. Low-speed, high-torque versions of this motor are currently under development to serve as direct-drive position servomotors in robotics applications. Preliminary specifications for this configuration, to be called the S225, are included in this document.

Call a Lynx applications engineer to determine if there is a 225 mm SEMA design that can meet your needs.



Lynx Motion Technology

9540 Highway 150
PO Box 250
Greenville, Indiana 47124-0250
<http://www.LynxMotionTechnology.com/>
Phone (812) 949-7924 • Fax (812) 949-7946

E225

Parameter	Symbol	SI	English
Continuous Ratings			
Supply Voltage (DC bus)	V_s	155 V _{DC}	155 V _{DC}
Voltage (phase voltage H-bridge)	V	117 V _{rms}	117 V _{rms}
Speed	S	6,000 rpm	6,000 rpm
Torque	T_c	9.9 N·m	7.3 lbf·ft
Current	I	18.7 A _{rms}	18.7 A _{rms}
Power	P_{out}	6.2 kW	8.3 hp
Peak Ratings			
Peak Torque ¹	T_{pk}	97.4 N·m	71.8 lbf·ft
Peak Current ¹	I_{pk}	180.0 A	180.0 A
Motor Constants			
Torque Constant	K_T	0.53 N·m/A	0.39 lbf·ft/A
Back EMF Constant (per phase)	K_E	19 V _{rms} /krpm	19 V _{rms} /krpm
Electrical Time Constant	τ_e	348 ns	348 ns
Electrical Aspects			
Resistance (100°C)	R	204 mΩ	204 mΩ
Inductance	L	71 μH	71 μH
Mechanical Aspects			
Inertia (rotor only)	J_r	18.4 g·m ²	2.60 ozf·in·s ²
Mass (entire motor)	m	8.4 kg	18.48 lb
Number of Poles	—	12 poles	12 poles
Motor Diameter (actual)	AC	225 mm	8.9 in.

¹ Peak ratings are extrapolated based on a one-second duty cycle assuming balanced load through all three phases starting with a coil temperature of 25°C and ending with a coil temperature of 100°C.

Efficiency (Motor Only)

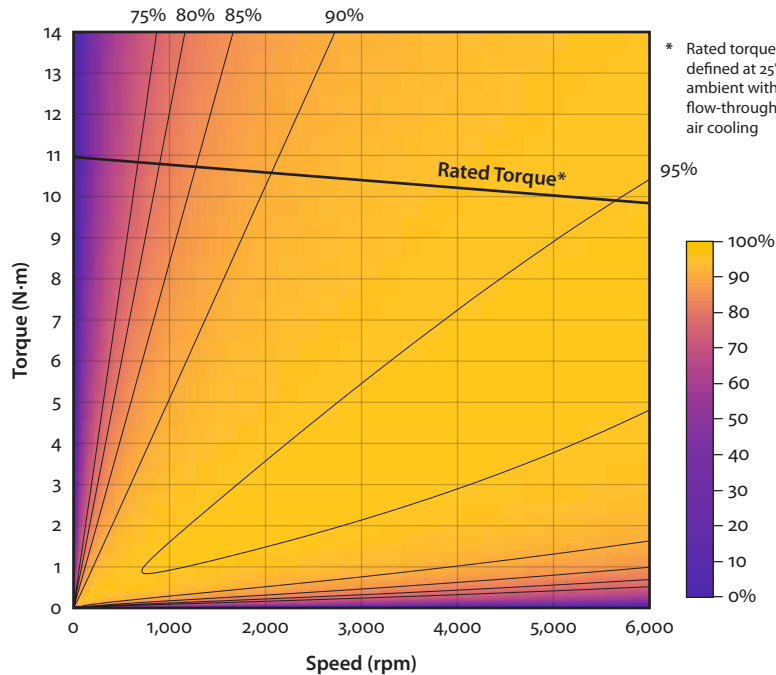

Lynx Motion Technology

9540 Highway 150

PO Box 250

Greenville, Indiana 47124-0250

<http://www.LynxMotionTechnology.com/>

Phone (812) 949-7924 • Fax (812) 949-7946

E225

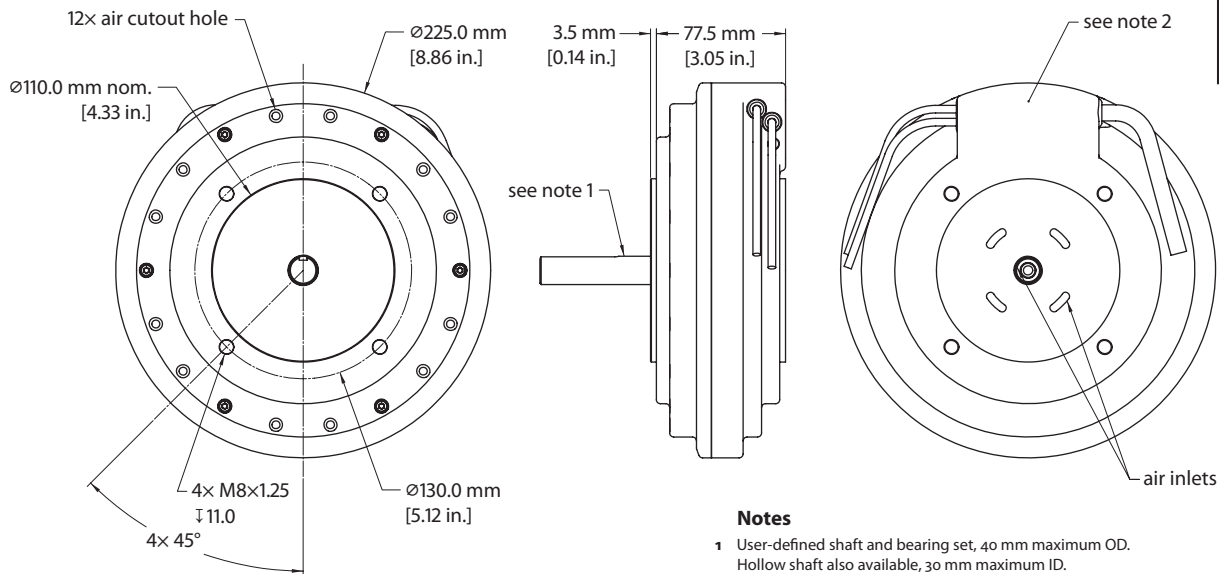

Notes

- 1 User-defined shaft and bearing set, 40 mm maximum OD. Hollow shaft also available, 30 mm maximum ID.
- 2 Terminating motor-power and Hall-effect cables standard. Connectors may be substituted, but will add axial length.

S225

Parameter	Symbol	SI	English
Continuous Ratings			
Supply Voltage (DC bus)	V_s	155 V _{DC}	155 V _{DC}
Voltage (phase voltage H-bridge)	V	144 V _{rms}	144 V _{rms}
Speed	S	1,000 rpm	1,000 rpm
Torque	T_c	12.5 N·m	9.2 lbf·ft
Current	I	3.8 A _{rms}	3.8 A _{rms}
Power	P_{out}	1.3 kW	1.7 hp
Peak Ratings			
Peak Torque ¹	T_{pk}	66.8 N·m	49.3 lbf·ft
Peak Current ¹	I_{pk}	19.9 A	19.9 A
Motor Constants			
Torque Constant	K_T	3.36 N·m/A	2.48 lbf·ft/A
Back EMF Constant (per phase)	K_E	117 V _{rms} /krpm	117 V _{rms} /krpm
Electrical Time Constant	τ_e	447 ns	447 ns
Electrical Aspects			
Resistance (100°C)	R	7.04 Ω	7.04 Ω
Inductance	L	3.36 mH	3.36 mH
Mechanical Aspects			
Inertia (rotor only)	J_r	18.4 g·m ²	2.60 ozf·in·s ²
Mass (entire motor)	m	8.6 kg	18.92 lb
Number of Poles	—	12 poles	12 poles
Motor Diameter (actual)	AC	225 mm	8.9 in.

¹ Peak ratings are extrapolated based on a three-second duration assuming balanced load through all three phases starting with a coil temperature of 25°C and ending with a coil temperature of 100°C.

Lynx Motion Technology

9540 Highway 150
 PO Box 250
 Greenville, Indiana 47124-0250
<http://www.LynxMotionTechnology.com/>
 Phone (812) 949-7924 • Fax (812) 949-7946